

AMG 7000 AND 9000 SERIES VIDEO ENCODER



QUICK START GUIDE

MOUNTING

Rack

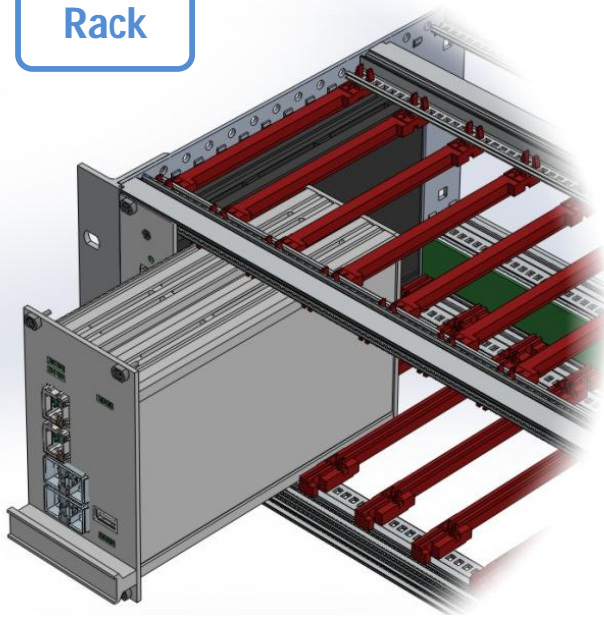

Stand Alone

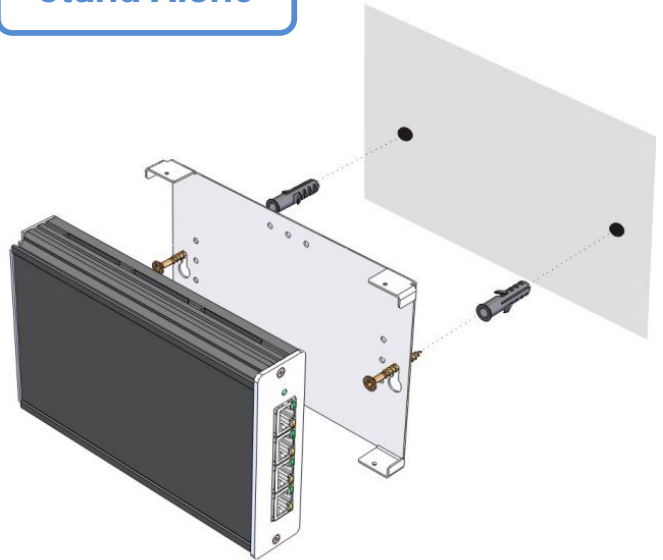

CONNECTIONS

Network

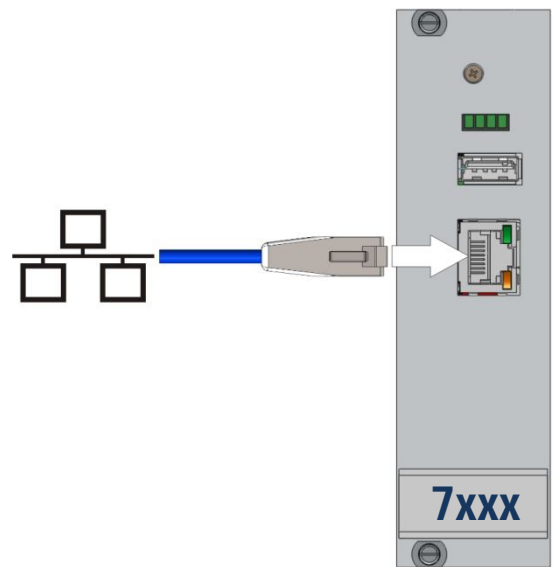
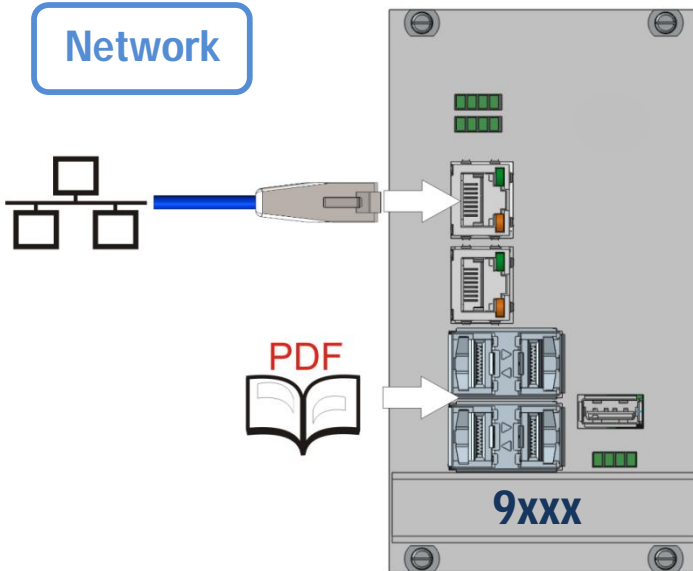

Camera Input

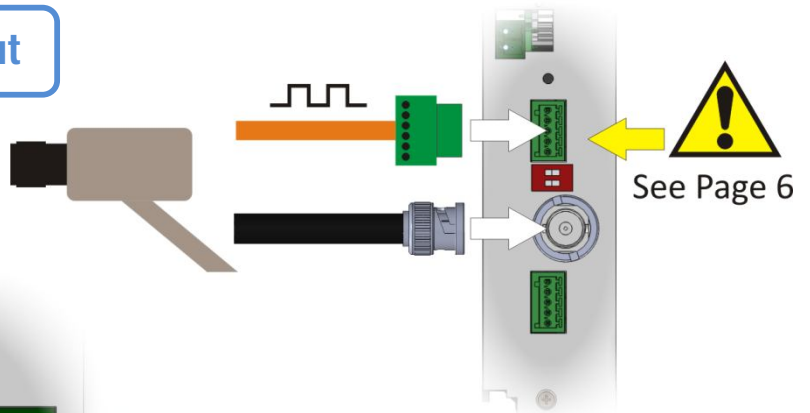

Power

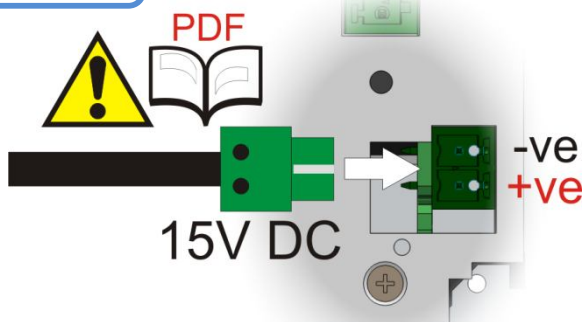

NETWORK SETTINGS & DISCOVERY-----

Fixed

DEFAULT SETTINGS

IP Address: 192.168.1.102
 Netmask: 255.255.255.0
 Gateway: 192.168.1.1

VIEWING PC SETTINGS

IP Address: 192.168.1.XXX
 Netmask: 255.255.255.0
 Gateway: 192.168.1.1

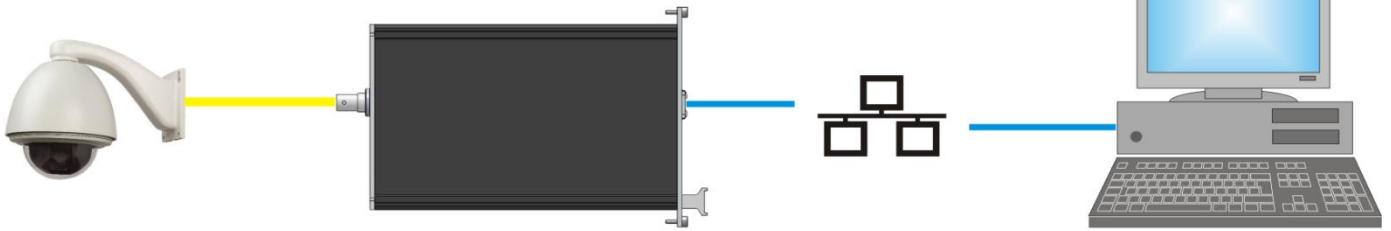

Or

DHCP

SETTINGS

IP Address: SET BY DHCP
 Netmask: SET BY DHCP
 Gateway: SET BY DHCP

AMG DISCOVERY APPLICATION

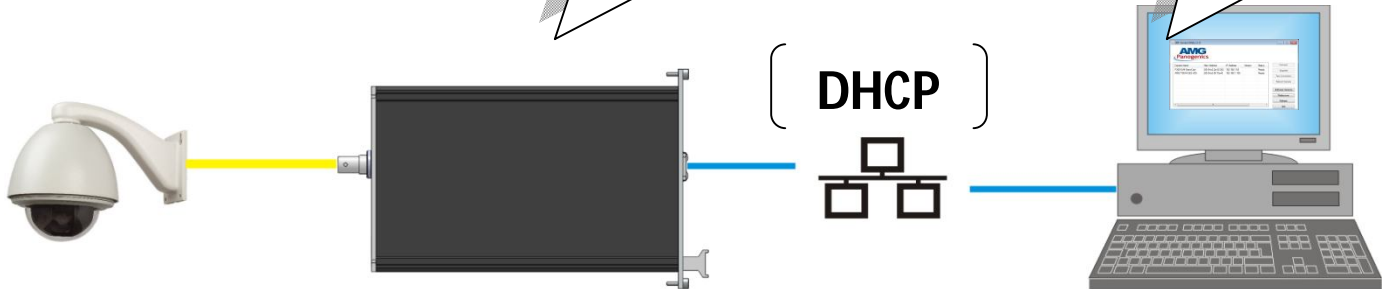

360 Camera Utility 1.1.0

AMG Panogenics

Camera Name	Mac Address	IP Address	Version	Status
P360-DJM-DemoCam	[00:04:a3:2e:63:36]	192.168.1.65		Ready
AMG7100-M-SES-VE5	[00:04:a3:9f:78:e4]	192.168.1.105		Ready

CONNECTION & VIEWING IMAGES-----

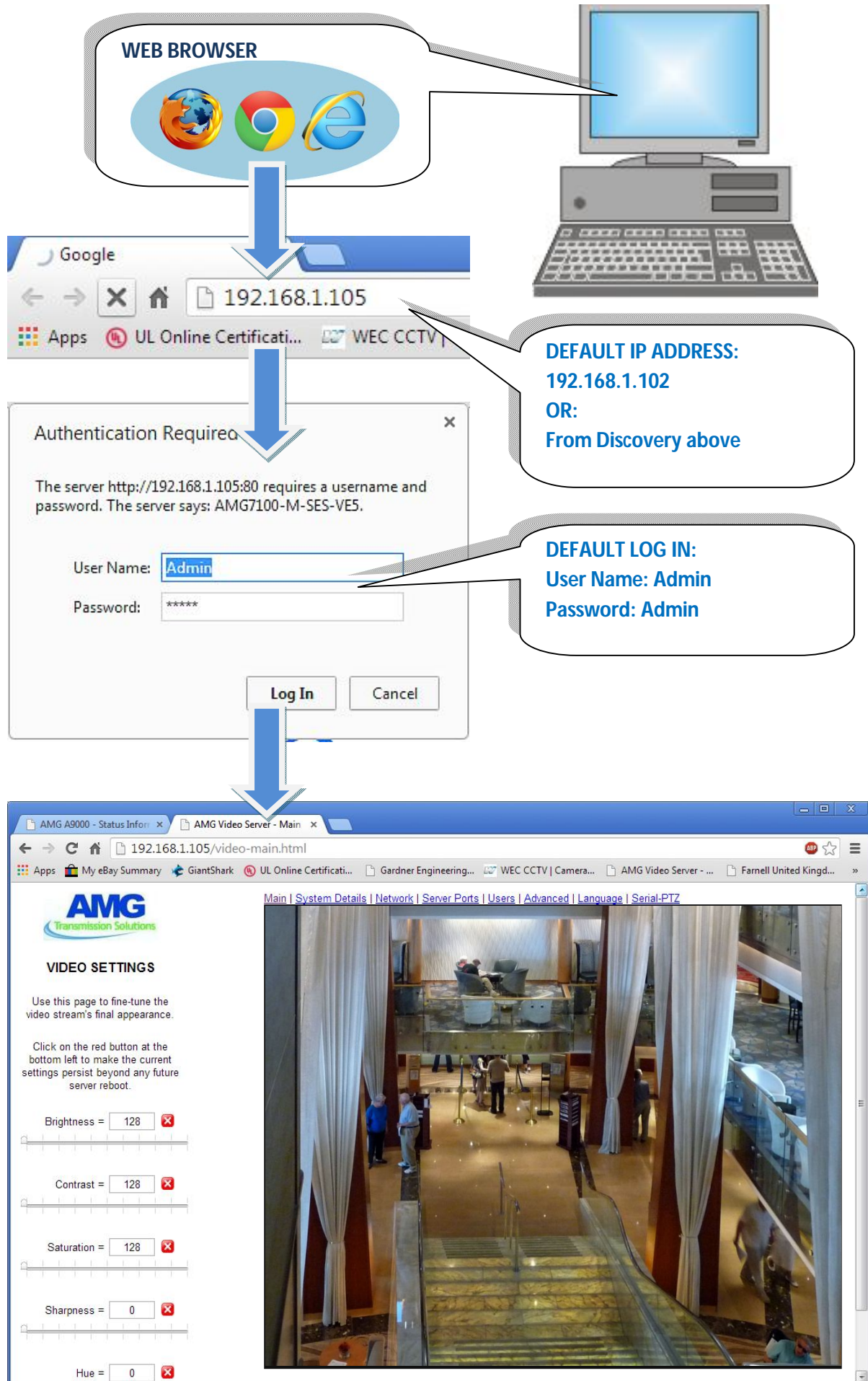

CHANGING THE IP ADDRESS

Open Network Page

AMG Transmission Solutions

Main | System Details | Network | Serv... | Users | Advanced |

NETWORK SETTINGS

IP Address	192	. 168	. 1	. 105
Gateway	192	. 168	. 254	. 254
Netmask	255	. 255	. 255	. 0
DHCP	<input type="checkbox"/>			
Server Name	M-SES-VE5			
MAC Address	00:04:A3:9F:78:E4			

Send Network Settings to Server

REBOOT SERVER

120s

Google

192.168.1.105

View With New Address

GETTING FURTHER HELP

USER GUIDE: PDF

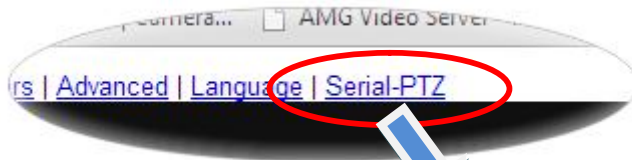
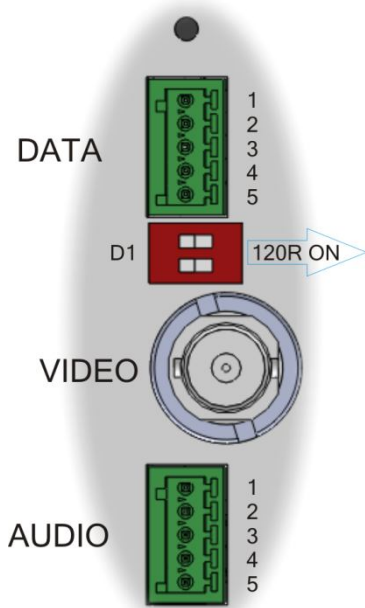

WEB: www.amgsystems.com
Phone +44 (0)1767 600 777

Data Connection & Settings



Protocol	Pin 1	Pin 2	Pin 3	Pin 4	Pin 5	Set	Baud	Parity	Data	Stop
Pelco D	Data -	Data +	Gnd	N/C	N/C	RS485	2400	No	7	1
RS232	TX (OUT)	N/C	Gnd	N/C	RX (IN)	RS232				

Technical Specifications

<p>Standards IEEE 802.3i 10Base-T IEEE 802.3u 100Base-TX</p> <p>Ethernet RJ45 Port</p> <p>Power (7000 Series) Input Voltage DC +15V 6 Watts max Recommended PSU: AMG2001 PSU PoE IEE 802.3af: Class 2 device</p> <p>Power (9000 Series) See main unit data sheet</p>	<p>General Operating Temperature: -20°C to +70°C Storage Temperature: -20°C to +85°C Ambient Relative Humidity: 0% to 95% (Non-condensing)</p> <p>Mechanical Casing: IP 30 Protection Metal case Rack mount 7HP or 14HP x 172 mm x 3U Weight: 1.5kg max Installation: Subrack or Wall Mount</p> <p>Regulatory CE EN55022 Class B EN61000 Class B</p> <p> </p> <p>© AMG Systems Ltd 3 The Omega Centre Stratton Business Park Biggleswade, Bedfordshire United Kingdom SG18 8QB</p>
---	--