

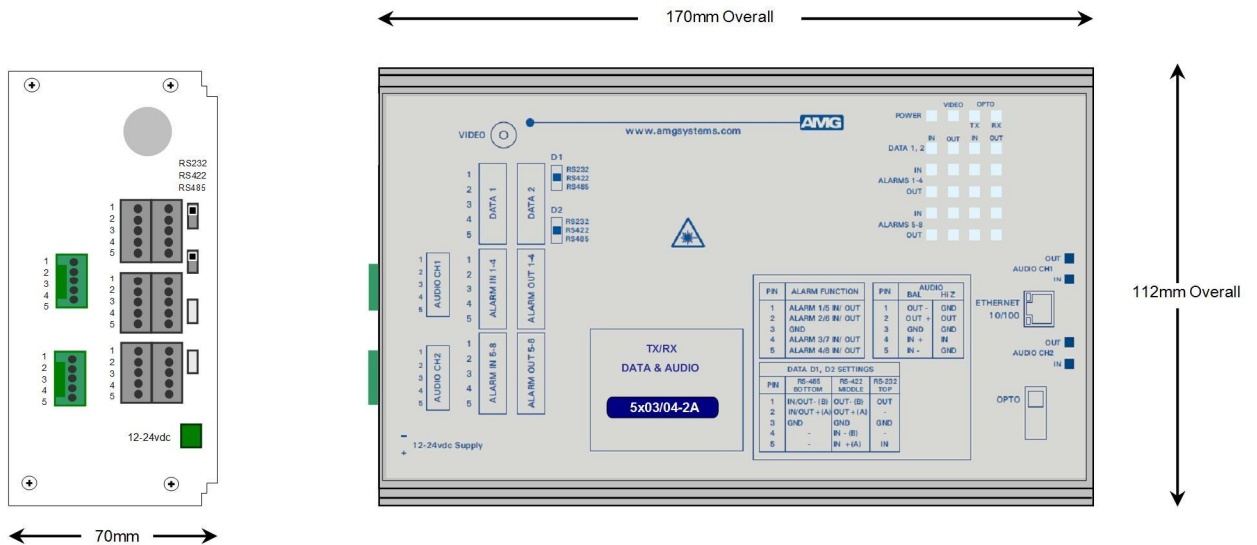

# AMG5904-2A9 Instruction Manual

**Receive Unit with two Bi-directional Data Channels, two Bi-directional Audio Channels, eight Bi-directional Alarms plus Ethernet for a Singlemode Fibre Link**



The **AMG5904-2A9** is a standalone data/audio receive unit designed to transmit and receive 2 data signals, 2 audio channels plus 8 bi-directional alarms and also provides full duplex 100Base-T Ethernet connectivity over a Singlemode optical fibre.

The **AMG5904-2A9** is designed to be powered using an **AMG2001** standalone power supply.

The **AMG5904-2A9** is designed to operate with an **AMG5903-2A9** or **AMG5903-2A9R** data transmit unit in a point to point configuration. The R suffix in the partno. indicates a rackmount configuration.

# Contents

|                                             |           |
|---------------------------------------------|-----------|
| <b>Introduction</b>                         | <b>3</b>  |
| Unit Functional Schematic.....              | 3         |
| Optical Connection.....                     | 3         |
| Ethernet Operation.....                     | 3         |
| <b>Connections</b>                          | <b>4</b>  |
| Power Connection.....                       | 4         |
| Optical Connection Singlemode .....         | 4         |
| Data and Alarm Channel Connections.....     | 4         |
| Audio Connections.....                      | 4         |
| Ethernet Connection .....                   | 5         |
| <b>Front Panel Indicators</b>               | <b>6</b>  |
| Power LED .....                             | 6         |
| Low Speed Data LEDs.....                    | 6         |
| Alarm LEDs .....                            | 6         |
| Ethernet Data LEDs.....                     | 6         |
| Audio LEDs.....                             | 6         |
| <b>Data and Alarm Channel Configuration</b> | <b>8</b>  |
| Data Channel Configuration .....            | 8         |
| Data Interface Connections.....             | 8         |
| Data Channel Termination .....              | 8         |
| Alarm Channel Configuration .....           | 9         |
| Alarm Channel Circuit.....                  | 9         |
| Alarm Interface Connections .....           | 10        |
| <b>Audio Channel Configuration</b>          | <b>11</b> |
| Audio Channel Configuration.....            | 11        |
| Audio Interface Connections Ch1 & Ch2 ..... | 11        |
| <b>Physical Information</b>                 | <b>12</b> |
| Dimensions.....                             | 12        |
| Mounting Details.....                       | 12        |
| <b>Safety</b>                               | <b>12</b> |
| <b>Maintenance and Repair</b>               | <b>12</b> |

## Introduction

### Unit Functional Schematic

The **AMG5904-2A9** transmits and receives 2 data channels, 2 bi-directional audio signals and 8 bi-directional alarm signals to/from the **AMG5903-2A9** transmit unit.

Ethernet connectivity is also provided between the two units.

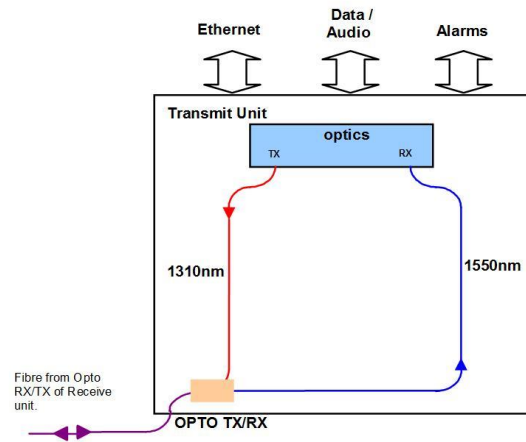

### Optical Connection

The **AMG5904-2A9** connections are illustrated in the following example which shows an **AMG5903-2A9** data transmit unit together with an **AMG5904-2A9** data receive unit configured as a point to point system.

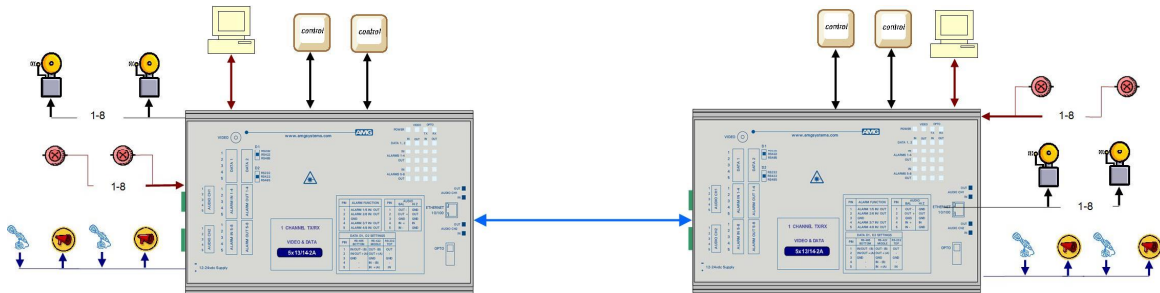

### Ethernet Operation

The Ethernet interface supports 100Mbit/s full duplex operation only. Data is transmitted from one port the other port with minimum delay or buffering.

The port implements "Auto MDI/MDIX" i.e. it may be connected with either a straight-through or cross-over cable to an appropriate device such as external switch, PC or other DCE/DTE.

Two LED indicators are provided adjacent to the RJ-45 port: Green indicates Link / Data transfer and Yellow indicates no Ethernet connection.

## Connections

---

### Power Connection

Connector Type ..... Removable 2-pin, 3.81mm, Screw Terminal  
Connector Partno..... Phoenix 1803578  
Supply Voltage..... +12 to +15 Volts DC  
Maximum Power ..... 5 Watts

### Optical Connection Singlemode

Optical Fibre ..... Singlemode  
Connector..... SC/PC

Primary Optical Launch Power ..... -10dBm  
Transmit Wavelength ..... 1550nm

Primary Optical Sensitivity..... -30dBm  
Receive Wavelength ..... 1310nm

Minimum Optical Dynamic Range ..... 20dB.

### Data and Alarm Channel Connections

No. of Data Channels..... 2  
No. of Alarms..... 8

Connectors ..... Removable 5-pin, 3.5mm, Spring Terminal  
Connector Partnos. .... Phoenix 1952296

Data Interfaces ..... RS-232 / 422 / 485. Selected by external slide switches D1-D2

RS-232 . Switch Position - Top  
RS-422 . Switch Position - Middle  
RS-485 . Switch Position - Bottom

Internal 120  $\Omega$  termination resistors may be applied to RS-422 or RS-485 inputs as required by internal DIL switches inside the enclosure. \*See appropriate section on how to remove the case for access to the DIL switches.

Alarm inputs..... Input is via a series 10k resistor with 47k  $\Omega$  pull-up to +3V3.  
Alarm outputs ..... Output is NPN open collector, maximum load 500mA @ 24Vdc.

### Audio Connections

No. of Audio Channels ..... 2

Connectors ..... Removable 5-pin, 2.5mm, Spring Terminal  
Connector Partno..... Phoenix 1881354

Input level ..... 0dBm  
Input overload level..... +6dBm

Input impedance ..... 10k  $\Omega$  / 600  $\Omega$   
Output impedance..... 600  $\Omega$

Frequency response ..... 10Hz to 20KHz

Audio Input impedance is selected by removable jumper JP1 or JP2 on Audio Expansion board inside enclosure. \*See appropriate section on how to remove the case for access to the data/audio switches.

1-2 . High Impedance 10k

2-3 . Balanced 600

***Ethernet Connection***

Ethernet Data Connector ..... RJ45

Interface ..... Auto MDI/MDIX 100BASE-TX

Ethernet Data Rate ..... Maximum 100Mb/s full duplex

## Front Panel Indicators

---

### Power LED

|               |       |   |                         |
|---------------|-------|---|-------------------------|
| POWER.....    | Green | - | Power is present        |
|               | Off   | - | Power is not present    |
| VIDEO .....   | Off   | - | Not used                |
| OPTO TX.....  | Green | - | Tx opto. present        |
|               | Off   | - | Tx opto. is not present |
| OPTO RX ..... | Green | - | Rx opto. sync.          |
|               | Off   | - | Rx opto. is not sync.   |

### Low Speed Data LEDs

|                                      |       |   |                                            |
|--------------------------------------|-------|---|--------------------------------------------|
| Data Present IN (RS485 or RS422).... | Green | - | logic zero (+V, -V) present on IN+, IN-    |
|                                      | Red   | - | logic one (-V,+V) present on IN+, IN-      |
|                                      | Off   | - | tri-state off or no connection on IN+, IN- |
| Data Present IN (RS232) .....        | Green | - | logic zero (+V) present on input IN+       |
|                                      | Red   | - | logic transitions present on input IN+     |
|                                      | Off   | - | logic one (-V) present on input IN+        |

IN corresponds to the data signals being transmitted onto the optical fibre.

|                                   |       |   |                                              |
|-----------------------------------|-------|---|----------------------------------------------|
| Data Present OUT (RS485 or RS422) | Green | - | logic zero (+V,-V) present on OUT+, OUT-     |
|                                   | Red   | - | logic one (-V,+V) present on OUT+, OUT-      |
|                                   | Off   | - | tri-state off or no connection on OUT+, OUT- |
| Data Present OUT (RS232) .....    | Green | - | logic zero (+V) present on OUT+              |
|                                   | Red   | - | logic transitions present on OUT+            |
|                                   | Off   | - | logic one (-V) present on OUT+               |

OUT corresponds to the data signals being received from the optical fibre.

### Alarm LEDs

#### Channels 1-8

|                |       |   |                             |
|----------------|-------|---|-----------------------------|
| ALARM IN ..... | Green | - | Alarm ON / Contacts closed. |
|                | Off   | - | Alarm OFF / Contacts open.  |
| ALARM OUT..... | Green | - | Alarm ON / Contacts closed. |
|                | Off   | - | Alarm OFF / Contacts open.  |

### Ethernet Data LEDs

|                        |        |   |                                    |
|------------------------|--------|---|------------------------------------|
| Link not Present ..... | Yellow | - | Link not present                   |
|                        | Off    | - | Link is present                    |
| Link Integrity .....   | Green  | - | Link integrity is good, Idle state |
|                        | GBlink | - | Data transfer                      |
|                        | Off    | - | Link not present                   |

### Audio LEDs

Audio Present TX..... Green - audio present > -40dBm  
Red - audio present > 0dBm (overload at +6dBm)  
Off - audio not present or < -40dBm

This represents the audio signals being transmitted on the optical fibre

Audio Present RX ..... Green - audio present > -40dBm  
Red - audio present > 0dBm (overload at +6dBm)  
Off - audio not present or < -40dBm

This represents the audio signals being received from the optical fibre.

## Data and Alarm Channel Configuration

The **AMG5904-2A9** receive unit sends and receives data to/from an **AMG5903-2A9** or rackmount equivalent **AMG5903-2A9R** transmit unit. The 2 physical data interfaces RS-485, RS-422 or RS-232 are individually selectable by the user with the slide switch mounted from the rear panel.

There are also 8 bi-directional alarm inputs provided, each alarm input is typically connected to a contact closure switch. Each alarm output can receive an on/off signal from an **AMG5903-2A9** and is typically used to convey contact closure status.

### Data Channel Configuration

Each low speed data channel provides an RS-232, RS-422 (full duplex, four wire) or RS-485 (half duplex, two wire) interface defined by the corresponding mode switch inside the enclosure. Every data channel as shipped from the factory is set up for RS-485 operation unless otherwise requested.

The data input for both the RS-485 and the RS-422 modes detects a tri-state input condition by monitoring the differential voltage level across the input. A differential level below 600mV positive or negative will be detected as a tri-state condition. A level above 600mV positive or negative will be detected as a logic 1 or logic 0 respectively. It is important therefore to terminate the RS-485 bus or the RS-422 input bus using 120  $\Omega$  if a pre-bias is present on the RS-485 or RS-422 bus.

A large number of third party equipment manufacturers apply a pre-bias on their RS-485 bus. This pre-bias is applied by pulling one arm of the RS-485 bus high (+5 volts) and the other arm low (0 volts) using high value resistors within the third party equipment. In order to ensure that the AMG equipment detects a tri-state condition, then these resistors should have a value above 5k  $\Omega$ . If the third party bias resistors are less than 750  $\Omega$  the bus can be multiple terminated as required to ensure that a tri-state level is detected.

The system detects a tri-state input condition on the data channel bus when in RS-485 or RS-422 mode.

### Data Interface Connections

| Connector Pin No. | Data Channel           |                        |                     |
|-------------------|------------------------|------------------------|---------------------|
|                   | RS-485 [switch bottom] | RS-422 [switch middle] | RS-232 [switch top] |
| 1                 | IN/OUT - (B)           | OUT - (B)              | OUT                 |
| 2                 | IN/OUT + (A)           | OUT + (A)              |                     |
| 3                 | GND                    | GND                    | GND                 |
| 4                 |                        | IN - (B)               |                     |
| 5                 |                        | IN + (A)               | IN                  |

Note: (A) or (B) in brackets in the above table refers to RS-485 / RS-422 data specification.

### Data Channel Termination

The interface mode RS-232, RS-422 or RS-485 of each data port Data 1-4, is selected with the corresponding external slide switch D1-D4. The actual number of data channels provided on the unit depends upon the AMG model.

Internal 120  $\Omega$  termination resistors across IN+ and IN- inputs may also be applied when in RS-422 or RS-485 mode using internal DIP switches P0-P3 on the main PCB inside the enclosure. P0-P3 may



be accessed by removing the 2 fixing screws in the rear panel and sliding the PCB out of the enclosure.

For clarity, in the 3 examples shown below all 4 data ports D1-D4 are terminated the same, but each data channel may be configured & terminated independently as required. The 3 examples shown are RS-232 (no termination), RS-422 (120  $\Omega$ ) or RS-485 (120  $\Omega$ ).

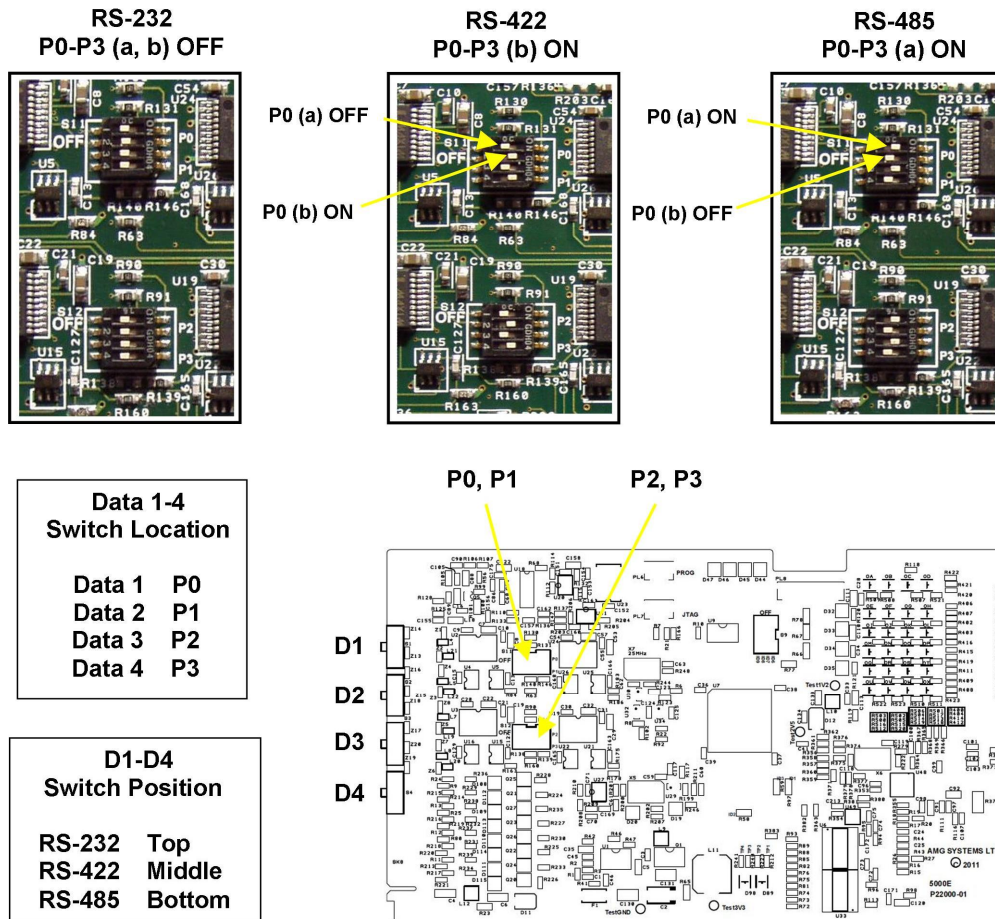

### Alarm Channel Configuration

The **AMG5904-2A9** provides 8 bi-directional contact closure inputs / alarm outputs. Each ALARM IN input is via an internal 10k  $\Omega$  series resistor with a 47k  $\Omega$  pull-up resistor to the internal +3V3 supply.

Each ALARM OUT output can receive an on/off signal from an **AMG5903-2A9** and is typically used to convey contact closure status. Each alarm output is NPN open collector, maximum load 500mA / 24Vdc.

### Alarm Channel Circuit

The output of each alarm channel is an NPN open collector transistor circuit, with an absolute maximum rating of 1A / 60V. There is a common GND for all alarm channels.

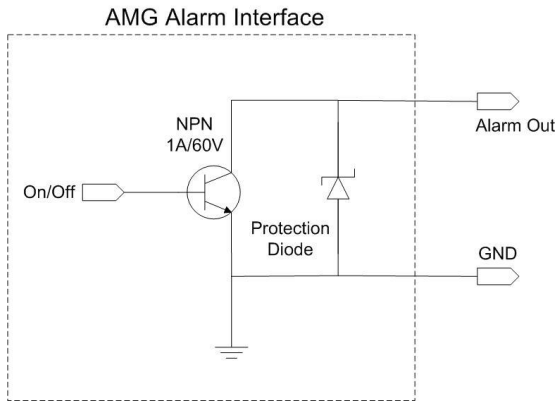

The alarm output circuit is designed for low dc voltage / low current operation and has minimal internal protection. If an alarm output is used to drive an external relay circuit, the external circuit **MUST** include a protection (flyback) diode connected across the relay to prevent the high voltage generated from a back EMF causing damage due to the AMG output transistor.

**Alarm Interface Connections**

| Connector Pin No. | Alarm Interfaces     |                       |
|-------------------|----------------------|-----------------------|
|                   | Alarm IN<br>1-4, 5-8 | Alarm OUT<br>1-4, 5-8 |
| 1                 | ALARM 1/5 IN         | ALARM 1/5 OUT         |
| 2                 | ALARM 2/6 IN         | ALARM 2/6 OUT         |
| 3                 | GND                  | GND                   |
| 4                 | ALARM 3/7 IN         | ALARM 3/7 OUT         |
| 5                 | ALARM 4/8 IN         | ALARM 4/8 OUT         |

## Audio Channel Configuration

---

### Audio Channel Configuration

The **AMG5904-2A9** provides two bi-directional audio channels.

Each audio channel input can be configured as a single-ended high impedance 10k  $\Omega$  input with GND reference or alternatively as a balanced 600  $\Omega$  input pair. The input impedance is selected using jumpers on the audio expansion board JP1 (Channel 1) or JP2 (Channel 2), the default setting is balanced 600  $\Omega$ .

JP1/JP2      1-2 . High Impedance 10k  
JP1/JP2      2-3 . Balanced 600

### Audio Interface Connections Ch1 & Ch2

| Connector Pin No. | Balanced Input 600 $\Omega$ | High Z input 10k $\Omega$ |
|-------------------|-----------------------------|---------------------------|
| 1                 | OUT -                       | OUT -                     |
| 2                 | OUT +                       | OUT +                     |
| 3                 | GND                         | GND                       |
| 4                 | IN +                        | IN                        |
| 5                 | IN -                        | GND                       |

## **Physical Information**

---

### **Dimensions**

Height..... 112mm  
Width..... 170mm (excluding connectors)  
Depth..... 70mm  
Weight..... 750grams

### **Mounting Details**

The AMG unit is supplied with a clip-on mounting bracket which should be attached to a panel or wall using 2 off 4.0mm screws, see diagram on page 1 for dimensions. The unit is clipped into the mounting bracket, and is then held firmly in position.

## **Safety**

---

AMG Optical Fibre Products use Class 1 laser systems in accordance with EN 60825-2:2000.

It is always advisable to follow good practice when working with optical fibre systems. This includes:

- Do not stare with unprotected eyes or with any unapproved collimating device at fibre ends or connector faces, or point them at other people.
- Use only approved filtered or attenuating viewing aids

For other safety issues and advice on good practice associated with optical fibre systems, please see EN 60825-2:2000 or your local safety officer.

## **Maintenance and Repair**

---

There are no user serviceable parts within AMG products. See unit data sheet for full specification. In case of problem or failure, please call your local support centre or contact: **AMG Systems Ltd.** at 3 The Omega Centre, Stratton Business Park, Biggleswade, Beds., SG18 8QB, UK.

|                   |                            |
|-------------------|----------------------------|
| Phone             | +44 (0) 1767 600 777       |
| Technical Support | +44 (0) 1767 604 491       |
| Email             | techsupport@amgsystems.com |