

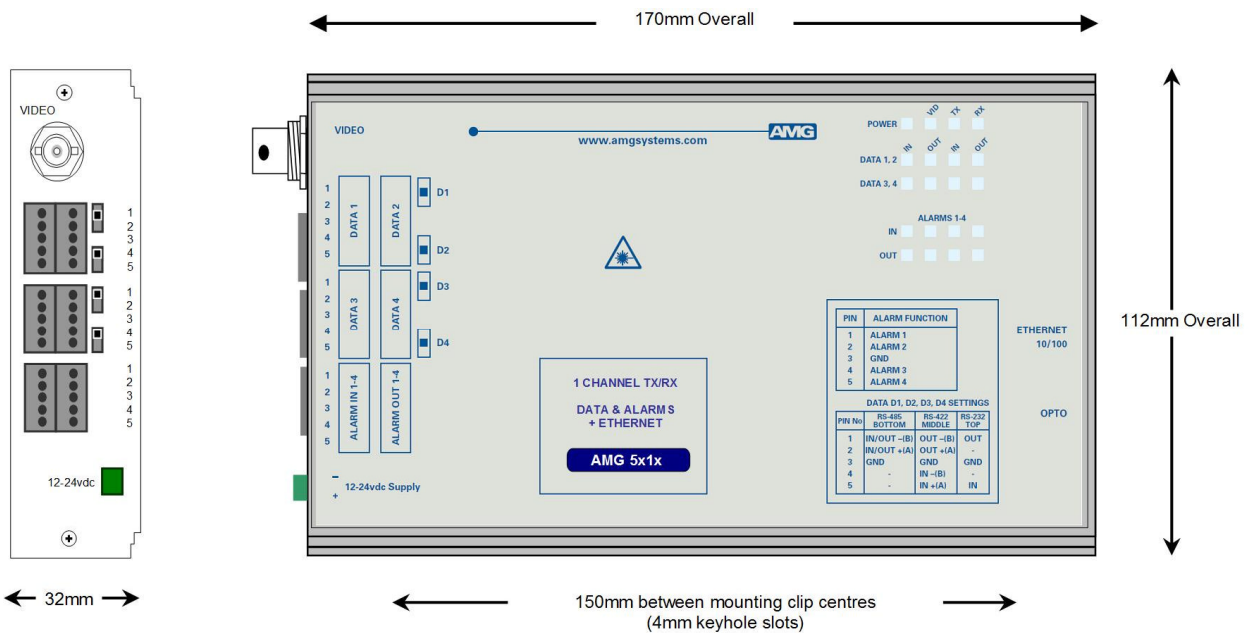

AMG5818 Instruction Manual

Single Channel Video Receive Unit with four Bi-directional Data Channels and four Bi-directional Alarms plus Ethernet for a Multimode Fibre Link



The **AMG5818** is a standalone one channel video receive unit designed to receive 1 video signal and transmit and receive 4 data signals plus 4 bi-directional alarms and also provides full duplex 100Base-T Ethernet connectivity over one Multimode optical fibre.

The **AMG5818** is designed to be powered using an **AMG2001** standalone power supply.

The **AMG5818** is designed to operate with an **AMG5817** or **AMG5817R** video transmit unit in a point to point configuration. The R suffix in the partno. indicates a rackmount configuration.

Contents

Introduction	3
Unit Functional Schematic.....	3
Optical Connection	3
Ethernet Operation	3
Connections	4
Video Output Connection	4
Optical Connection Multimode.....	4
Power Connection	4
Data and Alarm Channel Connections	4
Ethernet Connection.....	4
Front Panel Indicators	5
Power LED.....	5
Low Speed Data LEDs	5
Alarm LEDs.....	5
Ethernet Data LEDs.....	5
Data and Alarm Channel Configuration	6
Data Channel Configuration	6
Data Interface Connections	6
Data Channel Termination.....	6
Alarm Channel Configuration	7
Alarm Interface Connections	8
Physical Information	8
Dimensions	8
Mounting Details.....	8
Safety	8
Maintenance and Repair	8

Introduction

Unit Functional Schematic

The **AMG5818** receives 1 video, 4 data channels and 4 bi-directional alarm signals from the **AMG5817** transmit unit.

It also transmits 4 data channels and 4 bi-directional alarm signals to the **AMG5817**.

Ethernet connectivity is also provided between the two units.

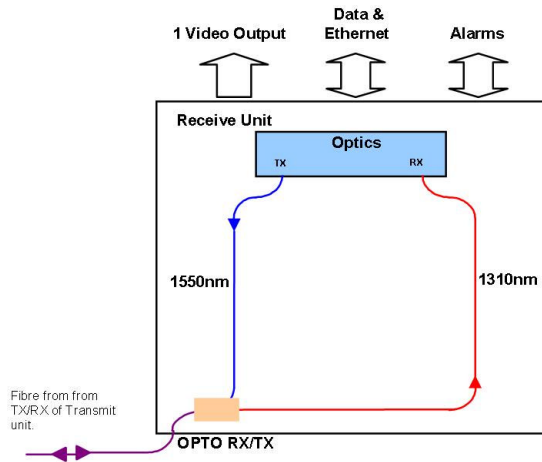

Optical Connection

The **AMG5818** connections are illustrated in the following example which shows an **AMG5817** single channel transmit unit together with a **AMG5818** configured as a point to point system.



Ethernet Operation

The Ethernet interface supports 100Mbit/s full duplex operation only. Data is transmitted from one port the other port with minimum delay or buffering.

The port implements "Auto MDI/MDIX" i.e. it may be connected with either a straight-through or cross-over cable to an appropriate device such as external switch, PC or other DCE/DTE.

Two LED indicators are provided adjacent to the RJ-45 port: Green indicates Link / Data transfer and Yellow indicates no Ethernet connection.

Connections

Video Output Connection

Connector 75 ohm BNC Socket.
Output Impedance 75 ohm terminated.
Output Level 1 Volt p-p nominal
Frequency Response..... 10Hz to 7MHz.

Optical Connection Multimode

Optical Fibre Multimode 50/125 or 62.5/125**
Connector SC/PC

Minimum Optical Launch Power -10dBm
Transmit Wavelength 1550nm
Minimum Optical Sensitivity -30dBm
Receive Wavelength 1310nm
Minimum Optical Dynamic Range 20dB.

**Note: the transmission distance is limited by the bandwidth of the Multimode optical fibre. The optical data rate is 155Mbps/s, which may restrict operation to a maximum fibre length of 7km, although in most cases the units will operate successfully over longer fibre lengths. It is advisable however for distances greater than 7km, to have the optical fibre tested.

Power Connection

Connector Type Removable 2-pin, 3.81mm, Screw Terminal
Connector Partno..... Phoenix 1803578
Supply Voltage..... +12 to +15 Volts DC
Maximum Power 2.5 Watts

Data and Alarm Channel Connections

No. of Data Channels 4
No. of Alarms 4

Connectors Removable 5-pin, 3.5mm, Spring Terminal
Connector Partnos..... Phoenix 1952296

Data Interfaces RS-232 / 422 / 485. Selected by external slide switches D1-D4
RS-232 – Switch Position - Top
RS-422 – Switch Position - Middle
RS-485 – Switch Position - Bottom

Internal 120Ω termination resistors may be applied to RS-422 or RS-485 inputs as required by internal DIL switches inside the enclosure. *See appropriate section on how to remove the case for access to the DIL switches.

Alarm inputs Input is via a series 10k resistor with 47kΩ pull-up to +3V3.
Alarm outputs..... Output is NPN open collector, maximum load 500mA @ 24Vdc.

Ethernet Connection

Ethernet Data Connector RJ45
Interface Auto-negotiation up to 100BASE-TX full duplex
Ethernet Data Rate Maximum 100Mb/s total Ethernet traffic on fibre

Front Panel Indicators

Power LED

POWER	Green	-	Power is present
	Off	-	Power is not present
VIDEO	Green	-	Video output signal is present
	Off	-	Video input signal is not present
OPTO TX.....	Green	-	Tx opto. present
	Off	-	Tx opto. is not present
OPTO RX	Green	-	Rx opto. sync.
	Off	-	Rx opto. is not sync.

Low Speed Data LEDs

Data Present IN (RS485 or RS422)	Green	-	logic zero (+V, -V) present on IN+, IN-
	Red	-	logic one (-V,+V) present on IN+, IN-
	Off	-	tri-state off or no connection on IN+, IN-
Data Present IN (RS232)	Green	-	logic zero (+V) present on input IN+
	Red	-	logic transitions present on input IN+
	Off	-	logic one (-V) present on input IN+

IN corresponds to the data signals being transmitted onto the optical fibre.

Data Present OUT (RS485 or RS422)	Green	-	logic zero (+V,-V) present on OUT+, OUT-
	Red	-	logic one (-V,+V) present on OUT+, OUT-
	Off	-	tri-state off or no connection on OUT+, OUT-
Data Present OUT (RS232)	Green	-	logic zero (+V) present on OUT+
	Red	-	logic transitions present on OUT+
	Off	-	logic one (-V) present on OUT+

OUT corresponds to the data signals being received from the optical fibre.

Alarm LEDs

Channels 1-4

ALARM IN.....	Green	-	Alarm ON / Contacts closed.
	Off	-	Alarm OFF / Contacts open.
ALARM OUT.....	Green	-	Alarm ON / Contacts closed.
	Off	-	Alarm OFF / Contacts open.

Ethernet Data LEDs

Link not Present	Yellow	-	Link not present
	Off	-	Link is present
Link Integrity	Green	-	Link integrity is good, Idle state
	GBlink	-	Data transfer
	Off	-	Link not present

Data and Alarm Channel Configuration

The **AMG5818** receive unit sends and receives data to/from an **AMG5817** or rackmount equivalent **AMG5817R** transmit unit. The 4 physical data interfaces RS-485, RS-422 or RS-232 are individually selectable by the user with the slide switch mounted from the rear panel.

There are also 4 bi-directional alarm inputs provided, each alarm input is typically connected to a contact closure switch. Each alarm output can receive an on/off signal from an **AMG5817** and is typically used to convey contact closure status.

Data Channel Configuration

Each low speed data channel provides an RS-232, RS-422 (full duplex, four wire) or RS-485 (half duplex, two wire) interface defined by the corresponding mode switch inside the enclosure. Every data channel as shipped from the factory is set up for RS-485 operation unless otherwise requested.

The data input for both the RS-485 and the RS-422 modes detects a tri-state input condition by monitoring the differential voltage level across the input. A differential level below 600mV positive or negative will be detected as a tri-state condition. A level above 600mV positive or negative will be detected as a logic 1 or logic 0 respectively. It is important therefore to terminate the RS-485 bus or the RS-422 input bus using 120Ω if a pre-bias is present on the RS-485 or RS-422 bus.

A large number of third party equipment manufacturers apply a pre-bias on their RS-485 bus. This pre-bias is applied by pulling one arm of the RS-485 bus high (+5 volts) and the other arm low (0 volts) using high value resistors within the third party equipment. In order to ensure that the AMG equipment detects a tri-state condition, then these resistors should have a value above 5kΩ. If the third party bias resistors are less the 750Ω the bus can be multiple terminated as required to ensure that a tri-state level is detected.

The system detects a tri-state input condition on the data channel bus when in RS-485 or RS-422 mode.

Data Interface Connections

Connector Pin No.	Data Channel		
	RS-485 [switch bottom]	RS-422 [switch middle]	RS-232 [switch top]
1	IN/OUT - (B)	OUT - (B)	OUT
2	IN/OUT + (A)	OUT + (A)	
3	GND	GND	GND
4		IN - (B)	
5		IN + (A)	IN

Note: (A) or (B) in brackets in the above table refers to RS-485 / RS-422 data specification.

Data Channel Termination

The interface mode RS-232, RS-422 or RS-485 of each data port Data 1-4, is selected with the corresponding external slide switch D1-D4. The actual number of data channels provided on the unit depends upon the AMG model.

Internal 120Ω termination resistors across IN+ and IN- inputs may also be applied when in RS-422 or RS-485 mode using internal DIP switches P0-P3 on the main PCB inside the enclosure. P0-P3 may

be accessed by removing the 2 fixing screws in the rear panel and sliding the PCB out of the enclosure.

For clarity, in the 3 examples shown below all 4 data ports D1-D4 are terminated the same, but each data channel may be configured & terminated independently as required. The 3 examples shown are RS-232 (no termination), RS-422 (120Ω) or RS-485 (120Ω).

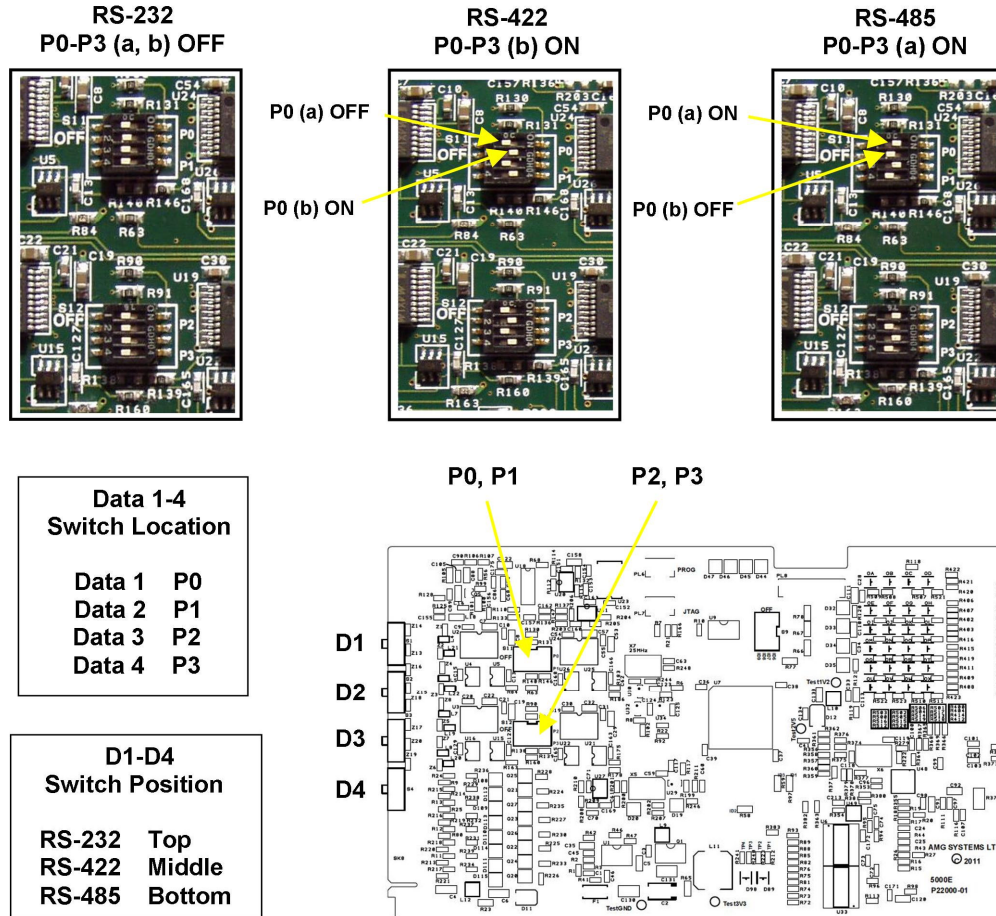

Alarm Channel Configuration

The **AMG5818** provides 4 bi-directional contact closure inputs / alarm outputs. Each ALARM IN input is via an internal 10kΩ series resistor with a 47kΩ pull-up resistor to the internal +3V3 supply.

Each ALARM OUT output can receive an on/off signal from an **AMG5817** and is typically used to convey contact closure status. Each alarm output is NPN open collector, maximum load 50mA / 24Vdc.

Alarm Interface Connections

Connector Pin No.	Alarm Interfaces	
	Alarm IN 1-4	Alarm OUT 1-4
1	ALARM 1 IN	ALARM 1 OUT
2	ALARM 2 IN	ALARM 2 OUT
3	GND	GND
4	ALARM 3 IN	ALARM 3 OUT
5	ALARM 4 IN	ALARM 4 OUT

Physical Information

Dimensions

Height..... 112mm
Width..... 170mm (excluding connectors)
Depth 35mm
Weight..... 200grams

Mounting Details

The AMG unit is supplied with a clip-on mounting bracket which should be attached to a panel or wall using 2 off 4.0mm screws, see diagram on page 1 for dimensions. The unit is clipped into the mounting bracket, and is then held firmly in position.

Safety

AMG Optical Fibre Products use Class 1 laser systems in accordance with EN 60825-2:2000.

It is always advisable to follow good practice when working with optical fibre systems. This includes:

- Do not stare with unprotected eyes or with any unapproved collimating device at fibre ends or connector faces, or point them at other people.
- Use only approved filtered or attenuating viewing aids

For other safety issues and advice on good practice associated with optical fibre systems, please see EN 60825-2:2000 or your local safety officer.

Maintenance and Repair

There are no user serviceable parts within AMG products. See unit data sheet for full specification.

In case of problem or failure, please call your local support centre or contact: **AMG Systems Ltd.** at 3 The Omega Centre, Stratton Business Park, Biggleswade, Beds., SG18 8QB, UK.

Phone +44 (0) 1767 600 777
Technical Support +44 (0) 1767 604 491
Email techsupport@amgsystems.com