

Single Channel Video Transmit Unit with one Bi-directional Data Channel and two Uni-directional Alarms for a Multimode Fibre Link

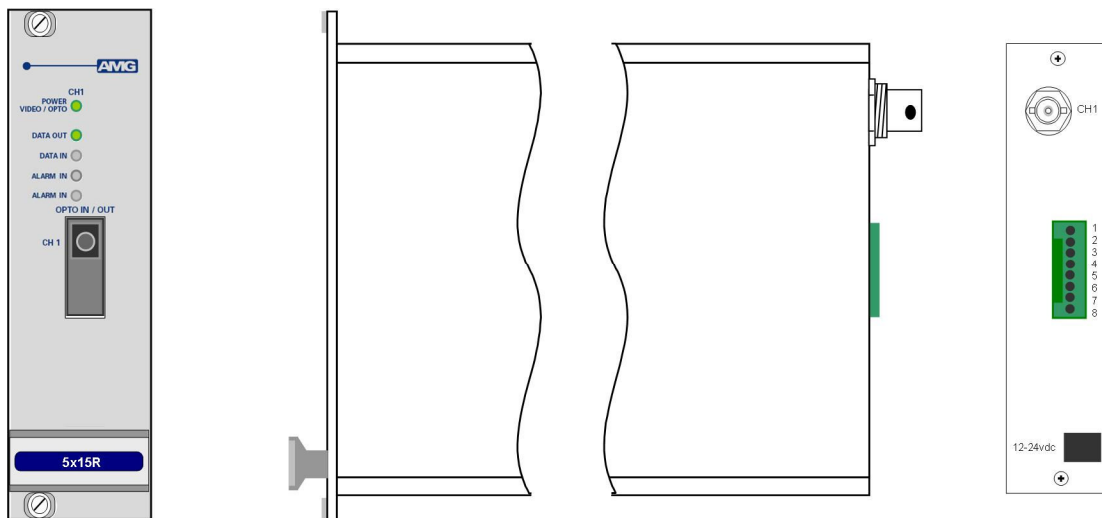

The **AMG5615R** is a rackmount one channel video transmit unit designed to transmit 1 video signal plus 2 Uni-directional alarms and transmit and receive 1 data signal over one Multimode optical fibre.

The **AMG5615R** is designed to plug into an **AMG2005** or **AMG2009** subrack, which in turn fits into a 19" rack system.

The **AMG5615R** is designed to operate with an **AMG5616** / **5616R** single channel or **AMG5626** / **5626R** dual channel video receive unit in a point to point configuration. The R suffix in the partno. indicates a rackmount configuration.

Contents

Introduction	3
Unit Functional Schematic.....	3
Optical Connection	3
Connections	4
Video Input Connections	4
Optical Connections Multimode.....	4
Power Connection	4
Data and Alarm Channel Connections	4
Front Panel Indicators	5
Power LED.....	5
Low Speed Data LEDs	5
Alarm LEDs.....	5
Data and Alarm Channel Configuration	6
Data Channel Configuration	6
Data Interface Connections	7
Alarm Channel Configuration	7
Alarm Interface Connections	7
Physical Information	8
Dimensions	8
Mounting Details	8
Safety	8
Maintenance and Repair	8

Introduction

Unit Functional Schematic

The **AMG5615R** transmits 1 video plus 1 data and 2 uni-directional alarm signals to the **AMG5616** receive unit.

It also receives 1 data signal transmitted from the **AMG5616**.

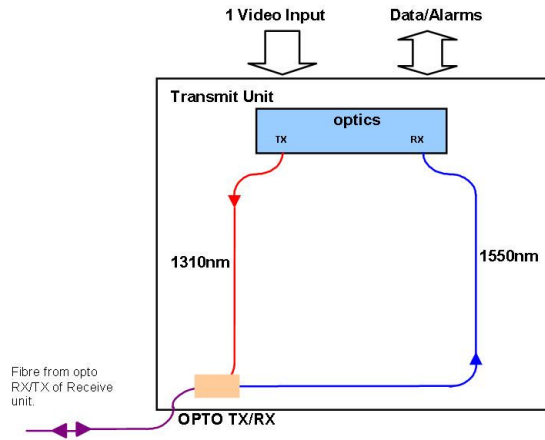

Optical Connection

The **AMG5615R** connections are illustrated in the following example which shows an **AMG5615R** transmit unit together with an **AMG5616R** single channel rackmount receive unit configured as a single channel point to point system.

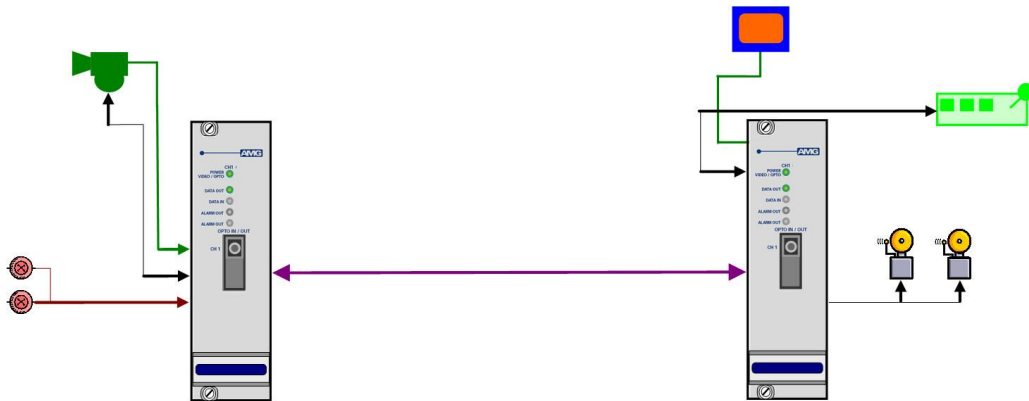

Connections

Video Input Connections

No. of channels 1
Connector 75 ohm BNC Socket.
Input Impedance 75 ohm terminated.
Input Level 1 volt p-p nominal
Frequency Response..... 10Hz to 7MHz.

Optical Connections Multimode

No. of Optical Connections 1 per video channel
Optical Fibre Multimode 50/125 or 62.5/125**
Connector SC/PC

Minimum Optical Launch Power -10dBm
Transmit Wavelength 1310nm

Minimum Optical Sensitivity -30dBm
Receive Wavelength 1510nm

Minimum Optical Dynamic Range 20dB.

**Note: the transmission distance is limited by the bandwidth of the Multimode optical fibre. The optical data rate is 155Mbits/s, which may restrict operation to a maximum fibre length of 7km, although in most cases the units will operate successfully over longer fibre lengths. It is advisable however for distances greater than 7km, to have the optical fibre tested.

Power Connection

Power supply From plug in connection on the AMG2009 or AMG2015 subrack
Power consumption 1.5 Watts max.

Data and Alarm Channel Connections

No. of Data Channels 1
No. of Alarms 2

Connectors Removable 8-pin, 2.5mm, Spring Terminal
Connector Partno..... Phoenix 1881383

Data Interfaces RS-232, RS-422 or R-S485. Selected by slide switch inside enclosure. *See appropriate section on how to remove the case for access to the data switches

RS-485 – Switch Position - Top
RS-422 – Switch Position - Middle
RS-232 – Switch Position - Bottom

Alarm inputs Contact Closure pull-up is 330R to +3V3

Front Panel Indicators

Power LED

Power / Video / Opto	Green	-	Video present & opto sync.
	R/G	-	Opto sync. but no video present.
	G/R	-	Video present but no opto sync.
	Red	-	No opto sync.
	Off	-	No power applied to unit

Low Speed Data LEDs

Data Present IN (RS485 or RS422)	Green	-	logic zero (+V, -V) present on IN+, IN-
	Red	-	logic one (-V, V+) present on IN+, IN-
	Off	-	tri-state off or no connection on IN+, IN-

Data Present IN (RS232)	Green	-	logic zero (+V) present on input IN+
	Red	-	logic transitions present on input IN+
	Off	-	logic one (-V) present on input IN+

IN corresponds to the data signals being transmitted onto the optical fibre.

Data Present OUT (RS485 or RS422)	Green	-	logic zero (+V, -V) present on OUT+, OUT-
	Red	-	logic one (-V, +V) present on OUT+, OUT-
	Off	-	tri-state off or no connection on OUT+, OUT-

Data Present OUT (RS232)	Green	-	logic zero (+V) present on OUT+
	Red	-	logic transitions present on OUT+
	Off	-	logic one (-V) present on OUT+

OUT corresponds to the data signals being received from the optical fibre.

Alarm LEDs

Channel 1

ALARM 1 IN.....	Green	-	Alarm ON / Contacts closed.
	Off	-	Alarm OFF / Contacts open.

ALARM 2 IN.....	Green	-	Alarm ON / Contacts closed.
	Off	-	Alarm OFF / Contacts open.

Channel 2

ALARM 1 IN.....	Green	-	Alarm ON / Contacts closed.
	Off	-	Alarm OFF / Contacts open.

ALARM 2 IN.....	Green	-	Alarm ON / Contacts closed.
	Off	-	Alarm OFF / Contacts open.

Data and Alarm Channel Configuration

The **AMG5615R** transmit unit sends and receives data to/from an **AMG5616** or rackmount equivalent **AMG5616R** receive unit. The physical data interface RS-485, RS-422 or RS-232 is selectable by the user with the slide switch mounted on the main PCB inside the enclosure.

Two uni-directional alarm channels are also provided. Each alarm input is typically connected to a contact closure switch.

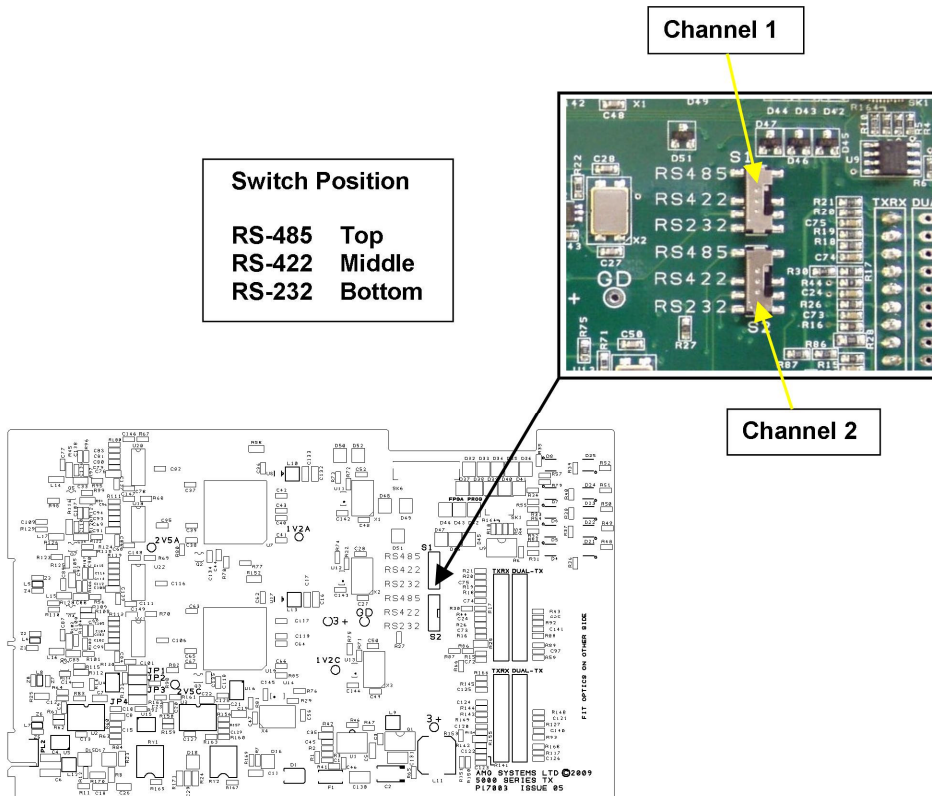

Data Channel Configuration

Each low speed data channel provides an RS-232, RS-422 (full duplex, four wire) or RS-485 (half duplex, two wire) interface defined by the corresponding mode switch inside the enclosure. Every data channel as shipped from the factory is set up for RS-485 operation unless otherwise requested.

The data input for both the RS-485 and the RS-422 modes detects a tri-state input condition by monitoring the differential voltage level across the input. A differential level below 600mV positive or negative will be detected as a tri-state condition. A level above 600mV positive or negative will be detected as a logic 1 or logic 0 respectively. It is important therefore to terminate the RS-485 bus or the RS-422 input bus using 120Ω if a pre-bias is present on the RS-485 or RS-422 bus.

A large number of third party equipment manufacturers apply a pre-bias on their RS-485 bus. This pre-bias is applied by pulling one arm of the RS-485 bus high (+5 volts) and the other arm low (0 volts) using high value resistors within the third party equipment. In order to ensure that the AMG equipment detects a tri-state condition, then these resistors should have a value above 5kΩ. If the third party bias resistors are less than the 750Ω the bus can be multiple terminated as required to ensure that a tri-state level is detected.

The system detects a tri-state input condition on the data channel bus when in RS-485 or RS-422 mode.

Data Interface Connections

Connector Pin No.	Data Channel		
	RS-485 [switch top]	RS-422 [switch middle]	RS-232 [switch bottom]
1		IN + (A)	IN
2		IN - (B)	
3	GND	GND	GND
4			
5			
6			
7	IN/OUT + (A)	OUT + (A)	
8	IN/OUT - (B)	OUT - (B)	OUT

Note: (A) or (B) in brackets in the above table refers to RS-485 / RS-422 data specification.

Alarm Channel Configuration

The **AMG5615R** provides two uni-directional alarm / contact closure inputs. Each alarm input is typically connected to a contact closure switch.

Each ALARM IN+ input incorporates a 330R pull-up resistor to the internal +3V3 supply.

Alarm Interface Connections

Connector Pin No.	Alarm Interface	
	Alarm 1	Alarm 2
1		
2		
3	ALARM 1 GND	
4	ALARM 1 IN +	
5		ALARM 2 GND
6		ALARM 2 IN +
7		
8		

Physical Information

Dimensions

Height.....3U Plug-in
Width.....7HP
Depth170mm excluding connectors
Weight.....200grams

Mounting Details

The unit is designed to be mounted within an AMG2009 or AMG2015 Subrack on standard card guides.

Safety

AMG Optical Fibre Products use Class 1 laser systems in accordance with EN 60825-2:2000.

It is always advisable to follow good practice when working with optical fibre systems. This includes:

- Do not stare with unprotected eyes or with any unapproved collimating device at fibre ends or connector faces, or point them at other people.
- Use only approved filtered or attenuating viewing aids

For other safety issues and advice on good practice associated with optical fibre systems, please see EN 60825-2:2000 or your local safety officer.

Maintenance and Repair

There are no user serviceable parts within AMG products. See unit data sheet for full specification.

In case of problem or failure, please call your local support centre or contact: **AMG Systems Ltd.** at 3 The Omega Centre, Stratton Business Park, Biggleswade, Beds., SG18 8QB, UK.

Phone	+44 (0) 1767 600 777
Technical Support	+44 (0) 1767 604 491
Email	techsupport@amgsystems.com