

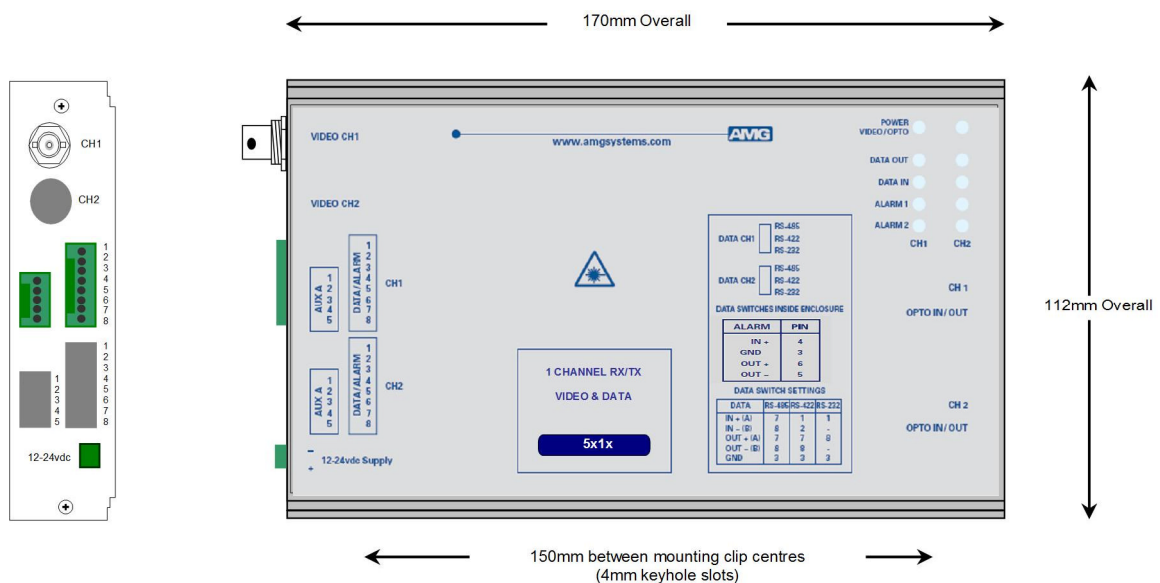

AMG5614A3 Instruction Manual

Single Channel Video Receive Unit with two Bi-directional Data Channels and one Bi-directional Alarm Channel for a Multimode Fibre Link



The **AMG5614A3** is a standalone one channel video receive unit designed to receive 1 video signal and transmit & receive 1 RS485/RS232/RS422 data signal and 1 20mA current loop data signal plus 1 Bi-directional alarm over a single Multimode optical fibre.

The **AMG5614A3** is designed to be powered using an **AMG2001** standalone power supply.

The **AMG5614A3** is designed to operate with an **AMG5613A3** / **AMG5613A3R** single channel transmit unit in a point to point configuration. The R suffix in the partno. indicates a rackmount configuration.

Contents

Introduction	3
Unit Functional Schematic.....	3
Optical Connection	3
Connections	4
Video Output Connections.....	4
Optical Connections Multimode.....	4
Power Connection	4
Data and Alarm Channel Connections	4
Front Panel Indicators	5
Power LED.....	5
Low Speed Data LEDs	5
Auxiliary Data LEDs.....	5
Alarm LEDs.....	5
Data and Alarm Channel Configuration	6
Data Channel Configuration	6
Data Interface Connections	7
Alarm Channel Configuration	7
Alarm Interface Connections	7
Auxiliary 20mA Current Loop Data Channel Configuration	8
Data Interface Connections	8
Physical Information	9
Dimensions	9
Mounting Details	9
Safety	9
Maintenance and Repair	9

Introduction

Unit Functional Schematic

The **AMG5614A3** receives 1 video signal plus 2 data and 1 bi-directional alarm signal from a **AMG5613A3** transmit unit.

It also transmits 2 data and 1 bi-directional alarm signal to a **AMG5613A3**.

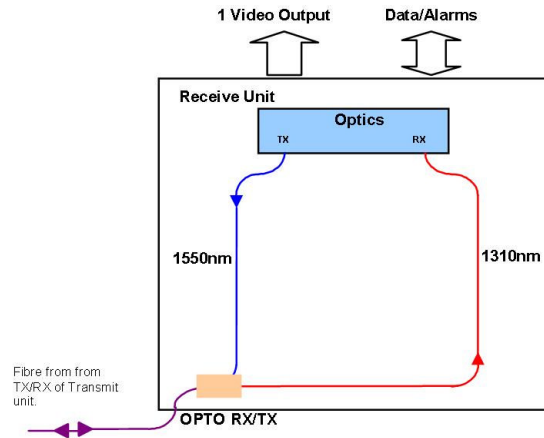

Optical Connection

The **AMG5614A3** connections are illustrated in the following example which shows an **AMG5613A3** transmit unit together with an **AMG5614A3** standalone receive unit configured as a single channel point to point system.

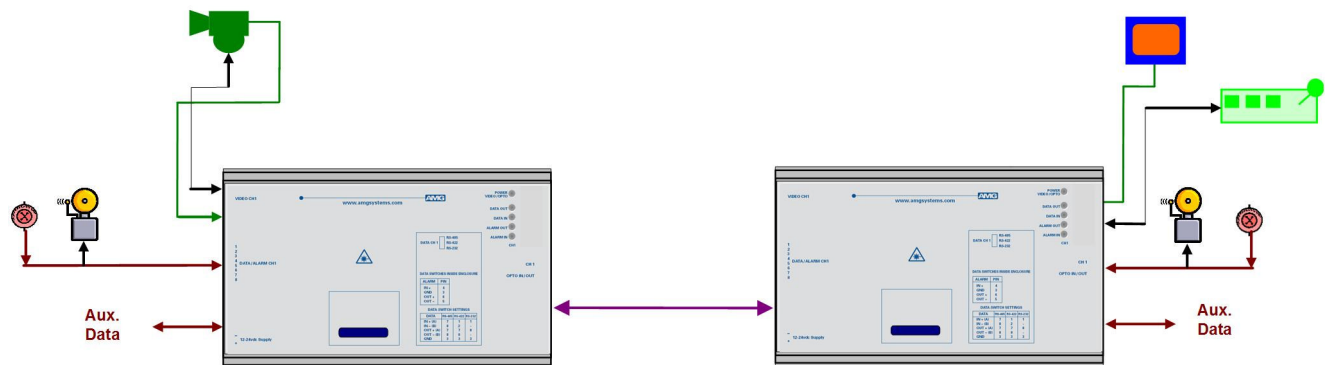

Connections

Video Output Connections

No. of channels 1
Connectors 75 ohm BNC Socket.
Output Impedance 75 ohm terminated.
Output Level 1 Volt p-p nominal
Frequency Response..... 10Hz to 7MHz.

Optical Connections Multimode

No. of Optical Connections 1 per video channel
Optical Fibre Multimode 50/125 or 62.5/125**
Connector SC/PC

Minimum Optical Launch Power -10dBm
Transmit Wavelength 1550nm

Minimum Optical Sensitivity -30dBm
Receive Wavelength 1310nm

Minimum Optical Dynamic Range 20dB.

**Note: the transmission distance is limited by the bandwidth of the Multimode optical fibre. The optical data rate is 155Mbps/s, which may restrict operation to a maximum fibre length of 7km, although in most cases the units will operate successfully over longer fibre lengths. It is advisable however for distances greater than 7km, to have the optical fibre tested.

Power Connection

Connector Type Removable 2-pin, 3.81mm, Screw Terminal
Connector Partno..... Phoenix 1803578
Supply Voltage +12 to +15 Volts DC
Maximum Power 1.5 Watts

Data and Alarm Channel Connections

No. of Integral Data Channels 1 Selectable RS-232 / RS-422 / RS-485
No. of Aux. Data Channels 1 20mA
No. of Alarms 1

Connectors Removable 5-pin, 8-pin, 2.5mm, Spring Terminal
Connector Partnos..... Phoenix 1881354, 1881383

Integral Data Interfaces RS-232, RS-422 or R-S485. Selected by slide switch inside enclosure. *See appropriate section on how to remove the case for access to the data switches

RS-485 – Switch Position - Top
RS-422 – Switch Position - Middle
RS-232 – Switch Position - Bottom

Alarm Input Contact Closure pull-up is 330R to +3V3
Alarm Output..... Solid-state Relay, maximum 150mA at 125Vac/dc, Ron < 6.5Ω

Front Panel Indicators

Power LED

Power / Video / Opto	Green	-	Video present & opto sync.
	R/G	-	Opto sync. but no video present.
	Red	-	No opto sync.
	Off	-	No power applied to unit.

Low Speed Data LEDs

Data Present IN (RS485 or RS422)	Green	-	logic zero (+V, -V) present on IN+, IN-
	Red	-	logic one (-V, V+) present on IN+, IN-
	Off	-	tri-state off or no connection on IN+, IN-

Data Present IN (RS232)	Green	-	logic zero (+V) present on input IN+
	Red	-	logic transitions present on input IN+
	Off	-	logic one (-V) present on input IN+

IN corresponds to the data signals being transmitted onto the optical fibre.

Data Present OUT (RS485 or RS422)	Green	-	logic zero (+V,-V) present on OUT+, OUT-
	Red	-	logic one (-V,+V) present on OUT+, OUT-
	Off	-	tri-state off or no connection on OUT+, OUT-

Data Present OUT (RS232)	Green	-	logic zero (+V) present on OUT+
	Red	-	logic transitions present on OUT+
	Off	-	logic one (-V) present on OUT+

OUT corresponds to the data signals being received from the optical fibre.

Auxiliary Data LEDs

Data type depends on AMG system: RS-232, RS-422, RS-485, 20mA, TTL, or FTT-10A

Data Present IN	Green	-	Data channel present but not transmitting
	R/G	-	Data channel transmitting
	Off	-	Data channel not present or no connection

IN corresponds to the data signals being transmitted onto the optical fibre.

Data Present OUT	Green	-	Data channel present but not transmitting
	R/G	-	Data channel receiving
	Off	-	Data channel not present or no connection

OUT corresponds to the data signals being received from the optical fibre.

Alarm LEDs

ALARM IN.....	Green	-	Alarm ON / Contacts closed.
	Off	-	Alarm OFF / Contacts open.

ALARM OUT.....	Green	-	Alarm ON / Contacts closed.
	Off	-	Alarm OFF / Contacts open.

Data and Alarm Channel Configuration

The **AMG5614A3** sends and receives data to/from a **AMG5613A3** single channel standalone transmit unit. The physical data interface RS-485, RS-422 or RS-232 is individually selectable by the user with the corresponding slide switch mounted on the main PCB inside the enclosure.

One bi-directional alarm is also provided. The alarm input is typically connected to a contact closure switch. The alarm output can receive an on/off signal from an **AMG5613A3** and is typically used to convey contact closure status.

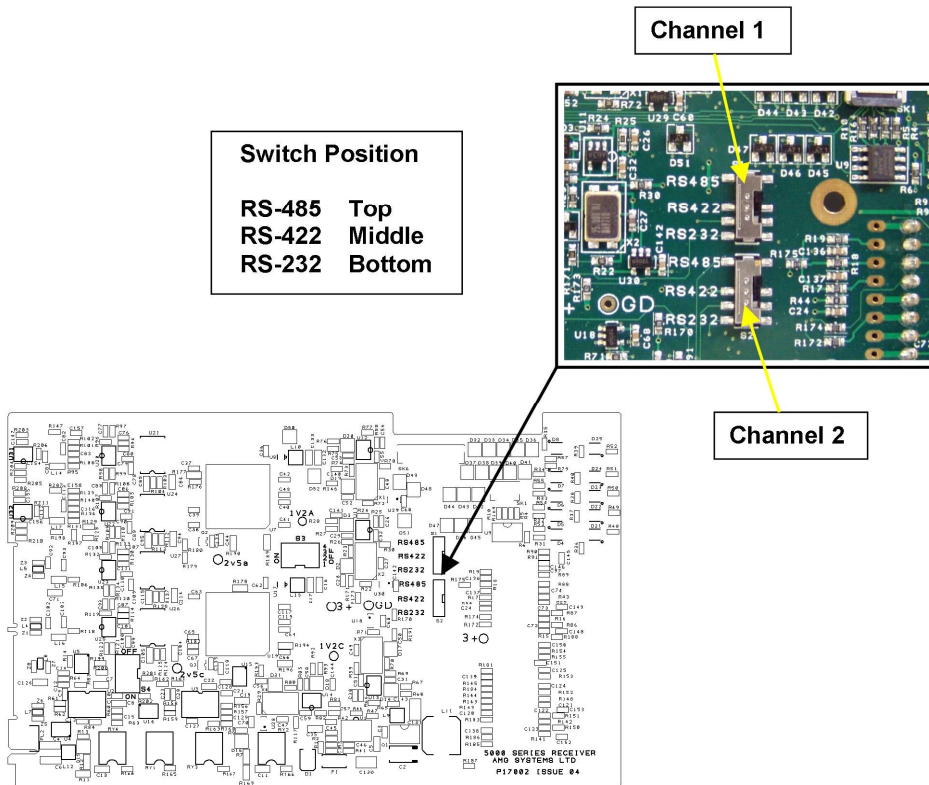

Data Channel Configuration

Each low speed data channel provides an RS-232, RS-422 (full duplex, four wire) or RS-485 (half duplex, two wire) interface defined by the corresponding mode switch inside the enclosure. Every data channel as shipped from the factory is set up for RS-485 operation unless otherwise requested.

The data input for both the RS-485 and the RS-422 modes detects a tri-state input condition by monitoring the differential voltage level across the input. A differential level below 600mV positive or negative will be detected as a tri-state condition. A level above 600mV positive or negative will be detected as a logic 1 or logic 0 respectively. It is important therefore to terminate the RS-485 bus or the RS-422 input bus using 120Ω if a pre-bias is present on the RS-485 or RS-422 bus.

A large number of third party equipment manufacturers apply a pre-bias on their RS-485 bus. This pre-bias is applied by pulling one arm of the RS-485 bus high (+5 volts) and the other arm low (0 volts) using high value resistors within the third party equipment. In order to ensure that the AMG equipment detects a tri-state condition, then these resistors should have a value above 5kΩ. If the third party bias resistors are less the 750Ω the bus can be multiple terminated as required to ensure that a tri-state level is detected.

The system detects a tri-state input condition on the data channel bus when in RS-485 or RS-422 mode.

Data Interface Connections

Connector Pin No.	Data Channel		
	RS-485 [switch top]	RS-422 [switch middle]	RS-232 [switch bottom]
1		IN + (A)	IN
2		IN - (B)	
3	GND	GND	GND
4			
5			
6			
7	IN/OUT + (A)	OUT + (A)	
8	IN/OUT - (B)	OUT - (B)	OUT

Note: (A) or (B) in brackets in the above table refers to RS-485 / RS-422 data specification.

Alarm Channel Configuration

The **AMG5614A3** provides one bi-directional alarm output / contact closure input per video channel.

The alarm input is typically connected to a contact closure switch. An ALARM IN+ input incorporates a 330R pull-up resistor to the internal +3V3 supply.

The alarm output can receive an on/off signal from an **AMG5613A3** and is typically used to convey contact closure status. An alarm output uses a solid-state relay, with a maximum load current of 150mA at 125Vac/dc and $R_{on} < 6.5\Omega$.

Alarm Interface Connections

Connector Pin No.	Alarm Interface	
	Alarm IN	Alarm OUT
1		
2		
3	GND	
4	ALARM IN +	
5		ALARM OUT -
6		ALARM OUT +
7		
8		

Auxiliary 20mA Current Loop Data Channel Configuration

The **AMG5614A3** receive unit sends and receives 20mA data to/from an **AMG5613A3** or rackmount equivalent **AMG5613A3R** transmit unit.

The auxiliary data channel is provided by an X04058 daughter board which provides one bi-directional 20ma current loop data channel over 4-wires.

The current loop will detect a 20mA current signal input through the IN+, I- terminals. It requires an active signal source, and will generate a matching 20mA signal at the other end of the link. The input IN+/IN- is isolated from GND, the output OUT- is connected to GND.

The maximum bit rate available is 2400bps.

The X04058 20mA current loop daughter board is pre-configured during manufacture to operate in Active Transmit / Passive Receive mode. There are no user adjustable features on this device.

Data Interface Connections

Connector Pin No	20mA current loop
1	OUT +
2	OUT -
3	GND
4	IN +
5	IN -

Physical Information

Dimensions

Height 112mm
Width 170mm (excluding connectors)
Depth 35mm
Weight 600grams

Mounting Details

The AMG unit is supplied with a clip-on mounting bracket which should be attached to a panel or wall using 2 off 4.0mm screws, see diagram on page 1 for dimensions. The unit is clipped into the mounting bracket, and is then held firmly in position.

Safety

AMG Optical Fibre Products use Class 1 laser systems in accordance with EN 60825-2:2000.

It is always advisable to follow good practice when working with optical fibre systems. This includes:

- Do not stare with unprotected eyes or with any unapproved collimating device at fibre ends or connector faces, or point them at other people.
- Use only approved filtered or attenuating viewing aids

For other safety issues and advice on good practice associated with optical fibre systems, please see EN 60825-2:2000 or your local safety officer.

Maintenance and Repair

There are no user serviceable parts within AMG products. See unit data sheet for full specification.

In case of problem or failure, please call your local support centre or contact: **AMG Systems Ltd.** at 3 The Omega Centre, Stratton Business Park, Biggleswade, Beds., SG18 8QB, UK.

Phone	+44 (0) 1767 600 777
Technical Support	+44 (0) 1767 604 491
Email	techsupport@amgsystems.com

This page is intentionally blank.

This page is intentionally blank.

This page is intentionally blank.